

Bag Dump

Unloading station



Application

The bag dump stations provide operators with an ergonomic solution for handling and manually dosing solid foodstuffs such as sugar, flour and salt, with similar grain sizes, in pre-weighed sacks or bags of approximately 25 kg.

They are used for minor ingredients within a production process.

They enable the introduction of different products to a (multi-product) production line.

Bag dump stations can be used for other non-foodstuff applications involving any type of solid material in powder form.

Operating principle

The equipment has an infeed hopper with a dust trapping system to mitigate dust cloud formation during loading.

The front hatch has a closing mechanism, with shock absorbers as a safety feature to prevent unintentional closure.

A vibrator and a rotary valve aid the emptying of the feeding hopper and the transportation of the raw material to the points of use. Different options and components are available to suit the product and equipment application, such as direct delivery, butterfly valves, extractors, and/or sieves. These elements enable transportation either in a vacuum or under pressure.

Design and features

Pneumatic cylinders as a safety system when closing the equipment's front hatch.

A protective grid inside the unit.

A fan for the dust trapping system with a filtering basket.

The filtering basket contains a polyester filter.

A stainless steel deflector that directs the dust cloud generated during loading to inside the equipment.

Bag emptying flow rates with a rotary valve or direct transportation of 3 T/hour* .

*Flow rates always depend on the product used and the installation conditions.

Bag Dump

Unloading station

Design and features

Types of raw material: flour, starch, leaf, grain, sugar and salt.

Solids level detector.

Pneumatic vibrator to aid raw material transfer.

Extraction components are pressurised when the raw material is sugar or salt.

Technical specifications

Materials:

Parts in contact with the product	AISI 316
Other materials	AISI 304
Protective elements	AISI 316
Seals in contact with the product	TR08 FDA cellular silicone

Surface finish:

Internal	2B, with stripped and polished welds $Ra \leq 0.8 \mu m$
External	2B, with brushed welds

Operating limits:

Capacities:	90 L and 200 L
Operating pressure:	Atmospheric
Operating temperature:	Ambient (equipment without insulation)

It is recommended to install the unloading stations in an area with controlled humidity and without flushing.

Options

Removable sanitary rotary valves.

Fine mesh sieves at the outlet of the bag dump station.

Extraction system: extractor or sieve fitting.

Non-standard ATEX marking.

In case of other configurations and products, please contact us.

Bag Dump

Unloading station

Dimensions of the Bag Dump station 90 L with a rotary unit ERS-200

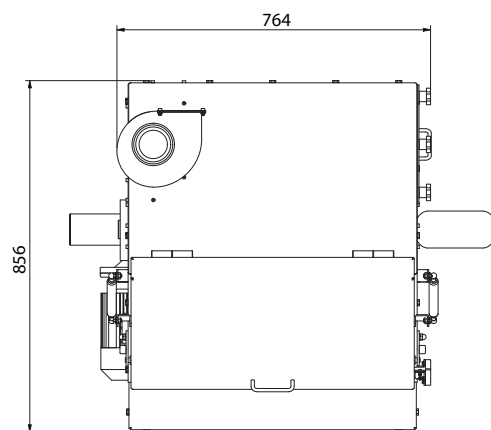
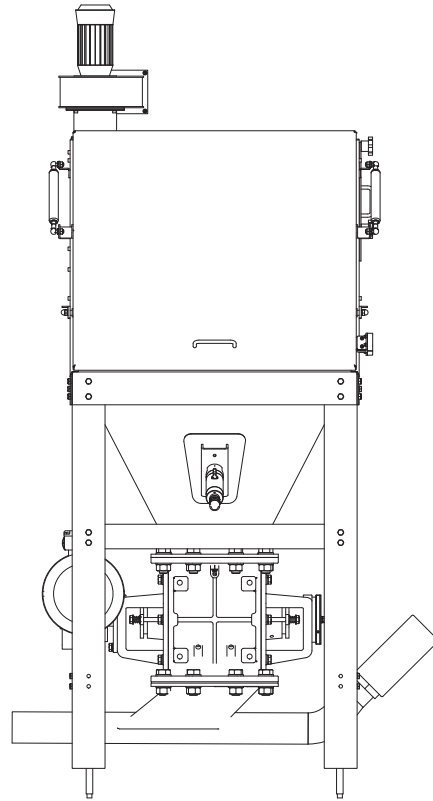
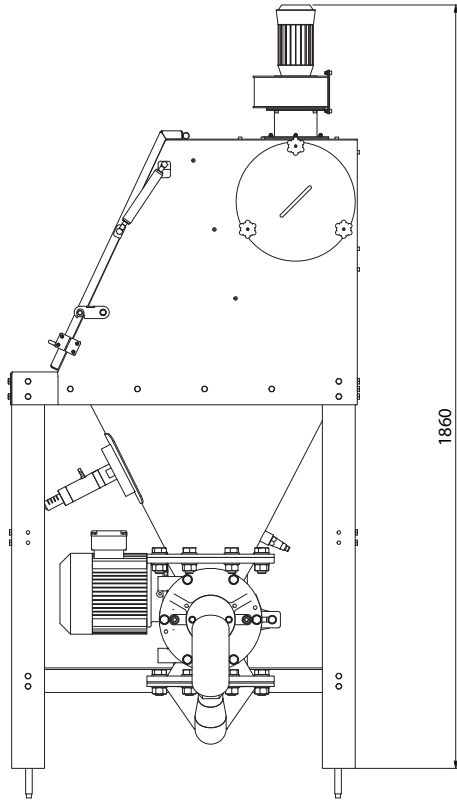

Bag Dump

Unloading station

Dimensions of the Bag Dump station 200 L with a rotary unit ERS-200

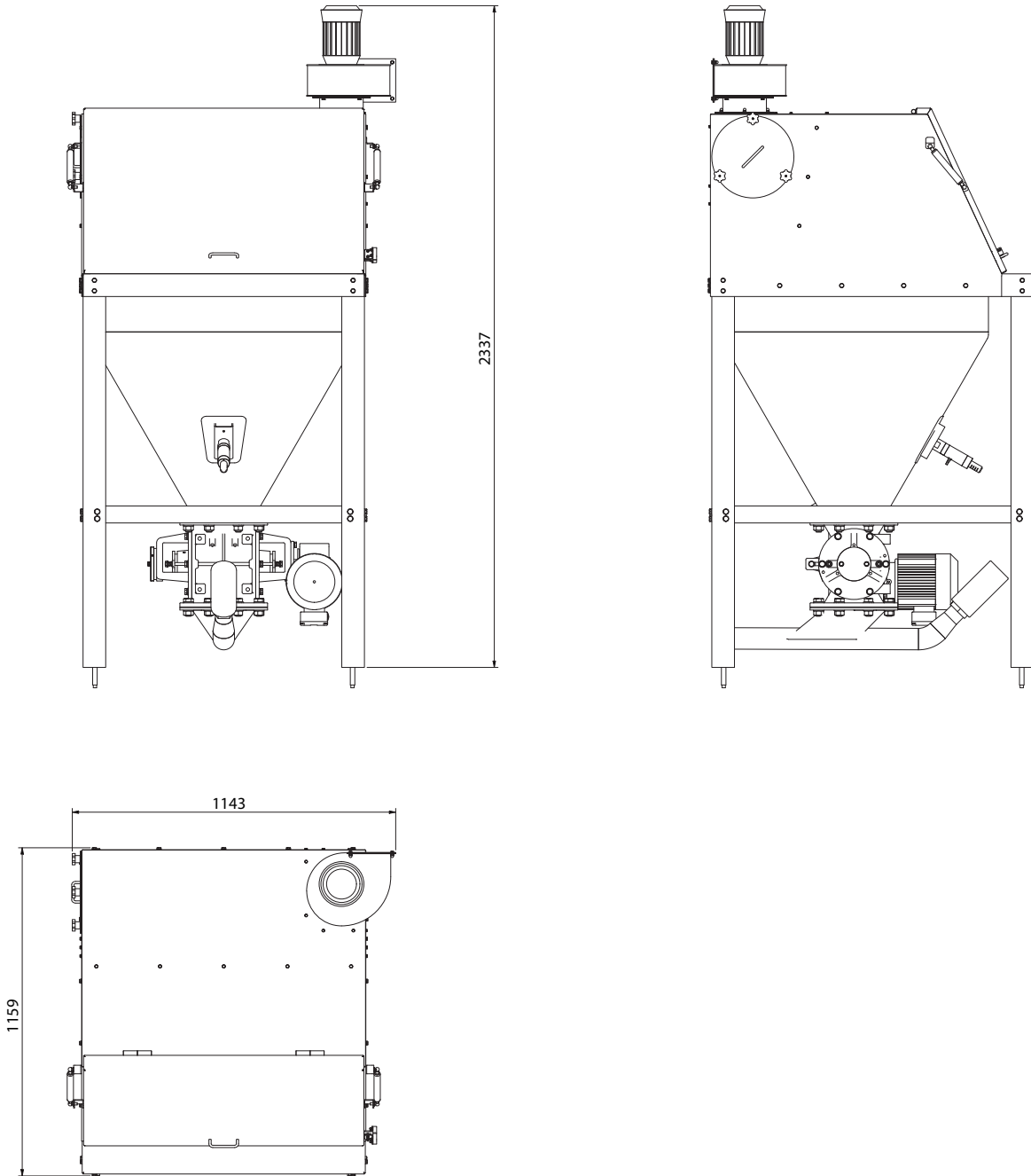

Bag Dump

Unloading station

Dimensions of the Bag Dump station 90 L with direct delivery

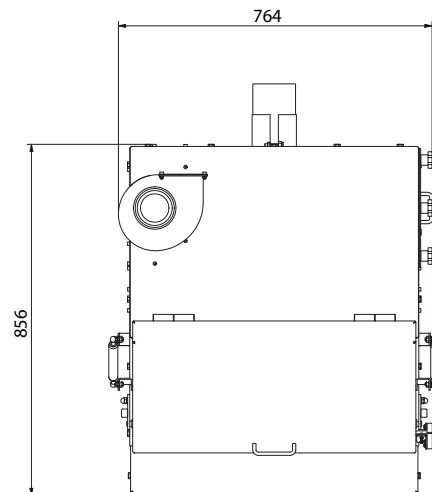
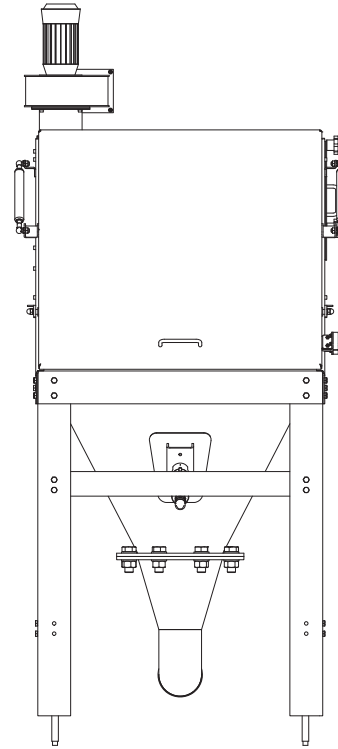
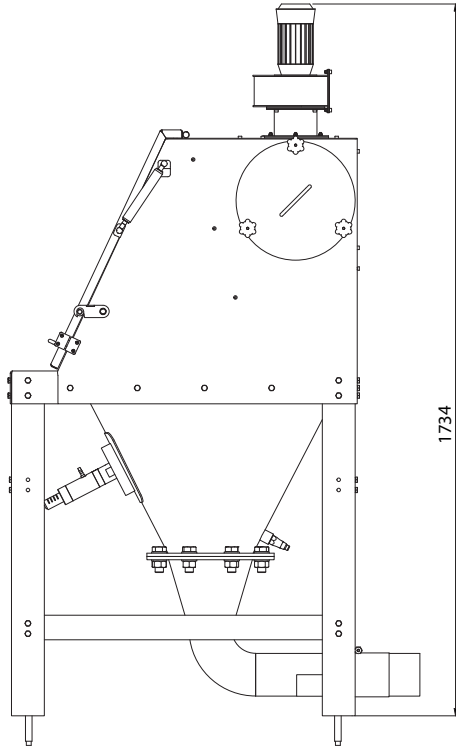

Bag Dump

Unloading station

Dimensions of the Bag Dump station 200 L with direct delivery

